



V.EPIR-A03052008

**ADNIL**



## EPIR-With Pet Immunity

### Passive Infrared Detector EPIR-With Pet Immunity

#### DESCRIPTION

- ADNIL passive infrared detector by means of dual element (model EPIR-A) or quad element (model EPIR-B) pyroelectric sensor immune to the temperature changes.
- Employs optically coupled MOSFET technology switches with super efficiency (only available for EPIR-A11 or B11).
- High immunity against false alarms and electro-magnetic fields.
- Manually adjustable sensibility, temperature compensation of alarm threshold for proper functioning in environments with notable temperature changes.
- Offers exceptional level of detection capability and stability for trouble-free installation.

#### FAMILY MODELS

- EPIR-A10 – Duo element detector with pet immunity and coil relay
- EPIR-A11 – Duo element detector with pet immunity and solid-state relay
- EPIR-B10 – Quad element detector with pet immunity and coil relay
- EPIR-B11 – Quad element detector with pet immunity and solid-state relay

#### SPECIFICATION

Infrared sensor	Dual element (EPIR-A) Quad element (EPIR-B)
Input voltage	9 ~ 16VDC, 12V (Recommended)
Current consumption	Standby ~9mA; Alarm ~38mA (Relay) 10-12mA (Solid -state)
Solid-state alarm output	100mA, N.C only
Coil relay alarm output	2A, N.C / N.O selectable
Alarm period	Approximately 1 second
Tamper switch	N.C
LED indicator	Red, can be disabled
Detectable speed	0.3 ~ 1m/sec
Dimension	117 x 66 x 45 mm
Unit weight	94g (EPIR-A10, B10) 90g (EPIR-A11, B11)
Operating temperature	-20°C ~ 60°C or -4°F ~ 140°F

#### INSTALLATION HINT

Avoid common false alarm sources specially DO NOT run cables parallel to AC main wires!!!

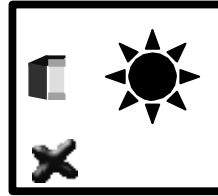

Avoid installing the detector facing directly or reflected by sunlight, car head lights, or bright surfaces such as mirror and windows.

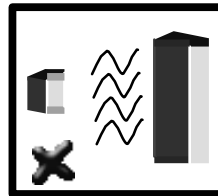

Avoid mounting the detector above air vents, lamps, or equipment that may change the environment temperature rapidly. These areas can radiate or direct heat over to cause nuisance tripping.

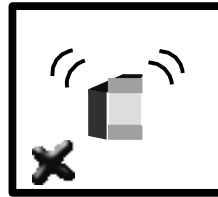

Mount the detector on a stable surface to prevent nuisance tripping caused by the vibration.

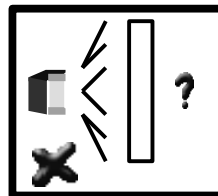

Ensure that there are no obstructions such as furniture, plants in the field of view, which may create a blind spot of the detector.

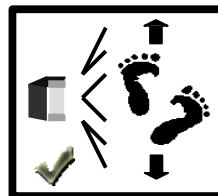

Detection is most effective when the movement is "across" the detection zones rather than "toward" the detector.

#### PARTS IDENTIFICATION

1	Cable knockout access
2	Terminal block
3	N.C / N.O jumper
4	LED ON / OFF jumper
5	LED
6	Tamper switch
7	Mounting setting
8	Infrared sensor (DO NOT TOUCH!)
9	Sensitivity adjustment jumper
10	Corner knockout

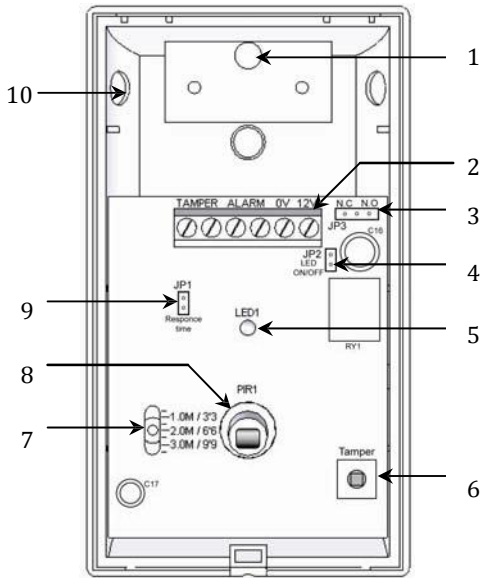

### INSTALLATION INSTRUCTION

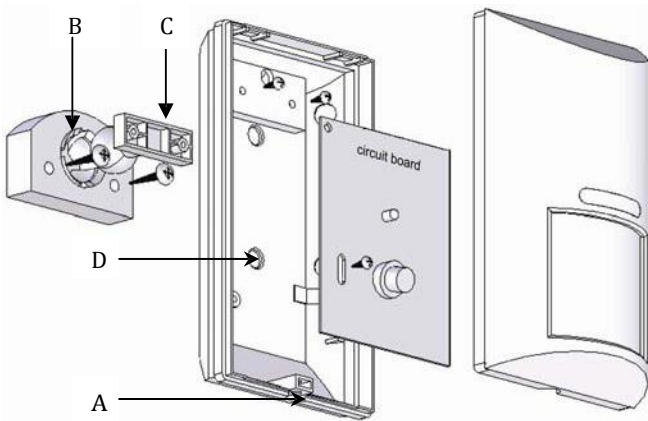

1. Open the top cover by loosening the screw at the bottom of the unit as shown at A.
2. Mounting the wall bracket onto the wall at height of 2m with screws as shown at B.
3. Insert the ball bracket (C) into the bottom back plate of the unit and tighten up with screws.
4. Connect the signal cables to the corresponding terminal accordingly.

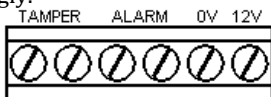

0V, 12V : 9 ~ 16 VDC, 12VDC recommended  
 ALARM : Zone input for alarm panel (N.C/N.O)  
 TAMPER : N.C loop for alarm panel

5. Insert the all unit after refit the top cover onto the wall bracket.
6. There are 6 knockouts provided for the wall mounting without the bracket. Ignore step 2 and 3 if installation without using wall bracket.
7. Remove the PCB from the base. Mount the base on the wall with selected position with at least 2 screws after remove the knockouts (D).
8. Refit the PCB onto the base and replace the top cover, apply the power supply to the detector and conduct a walk test.

### WALK TEST

Wait approximate 1.5 minutes after applying 12VDC power for the warm up and stabilize time. Conduct a testing with the protected area cleared of all people. Walk test should be conducted at least once a year to confirm proper operation and coverage of the detector.

1. Wait until the LED is off.
2. Walk across the detection zones with a normal speed.
3. The LED will turn on whenever it detects a movement.
4. Allow 8-11 seconds between each test for the detector to stabilize.
5. The LED display can be disabled by pulling off the jumper at location J2 labeled as "ON/OFF".

### SENSITIVITY ADJUSTMENT

Use the sensitivity adjustment jumper (JP1) to select high / low sensitivity. Placing on the jumper cap indicates HIGH sensitivity selection; remove the cap for LOW sensitivity selection.

### PET IMMUNITY

The Pet Immunity system is being embedded into the board, which is set to factory default setting.

### MOUNTING SETTING

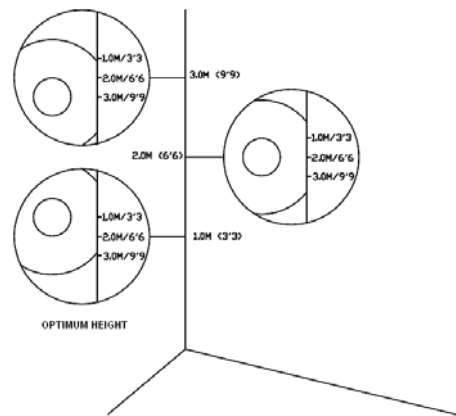

### COVERAGE PATTERN

